

Tech Solutions for Deaf Athletes

Name (s) _____

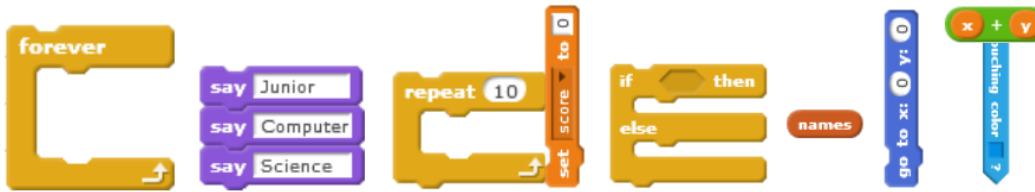

1, The BIG idea

Example Before any exercise the coach sets a pattern of lights. Red meaning rest, amber meaning gentle exercise and green meaning flat out. The deaf athlete responds to these during the exercise.

2, Map the circuit

Computer

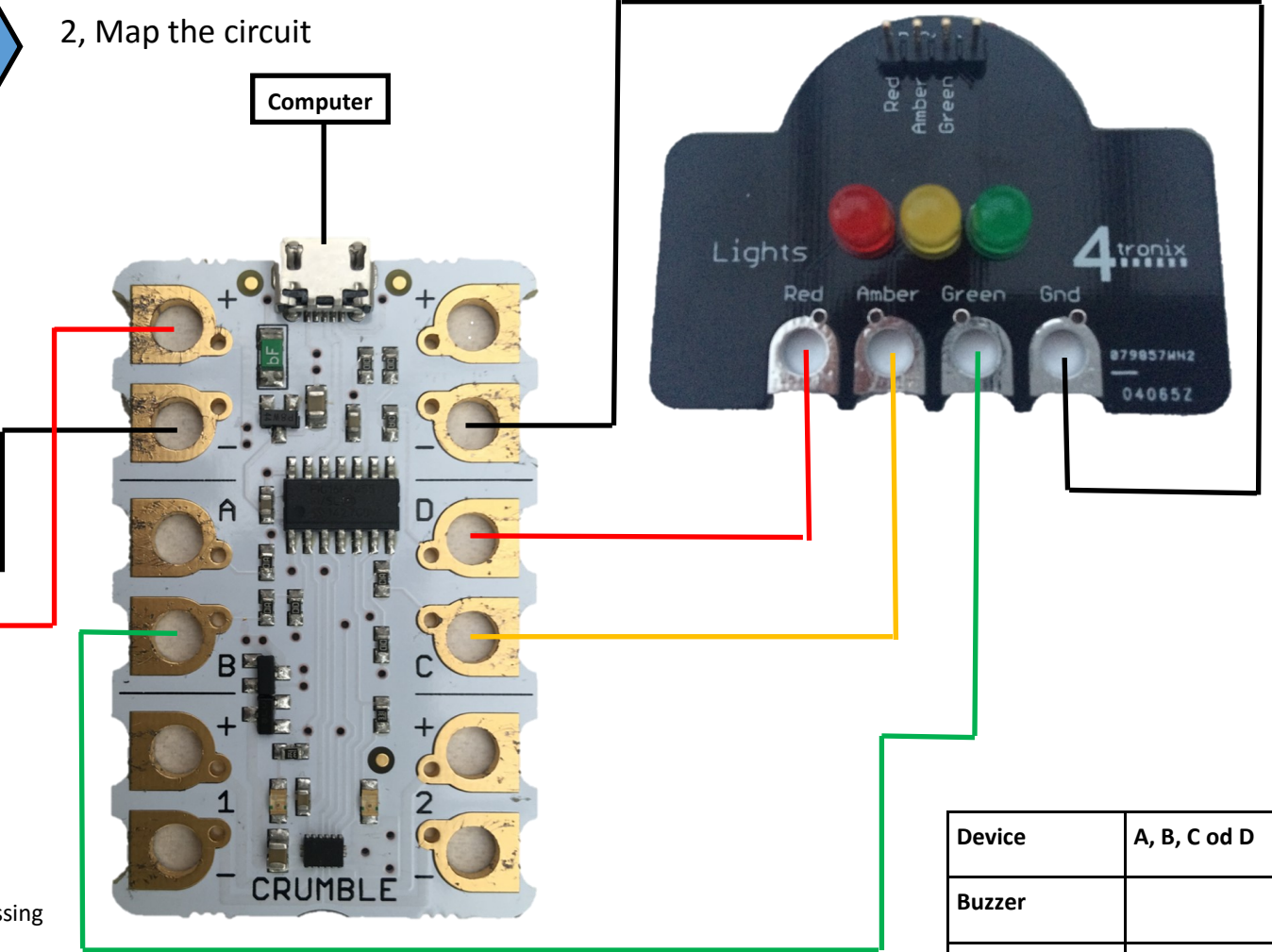

Use a ruler to draw lines. Draw in colours and try to avoid crossing lines wherever possible

| Device | A, B, C od D |
|--------|--------------|
| Buzzer | |
| Trig | |
| Echo | |